

Instruction Manual for FrSky S6R&S8R (SxR)

Introduction	1
Overview	1
Specifications	2
Features	2
Channels	2
Quick Mode	3
Flight Mode	3
Normal model	4
Delta wing (Elevon) & Flying wing & V-tail	4
Configuration	5
FrSky transmitter	5
PC software Freelink	5
Preflight Preparation	10
Inspection of flight attitude	10
Self-check	11
Setup Procedure	11

Introduction

Thank you for purchasing FrSky S6R/S8R (SxR instead in this manual) multi-function telemetry receiver. Equipped with built-in 3-axis gyroscope and accelerometer, SxR supports various functions. In order to fully enjoy the benefits of this system, please read the instruction manual carefully and set up the device as described below.

Overview

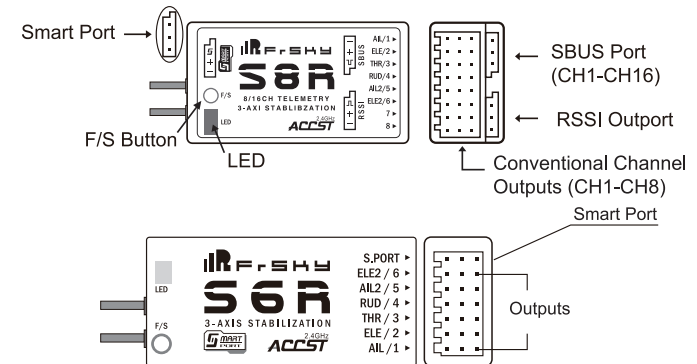

Rx states

Green LED	Red LED	State
ON	Flashing	Binding
Flashing	OFF	Normal
OFF	Flashing	Signal lost

Calibration of Accelerometer

Yellow LED	State
Flashing	Saving orientation information
Flashing Stop	Ready for next orientation calibration

Self-check

Blue LED	State
On	Start & In process
Off	Stick calibration ready

Accelerometer sensor

Yellow LED	State
ON	Exceeding stable limits [0.9G, 1.1G]
OFF	Within stable limits [0.9G, 1.1G]
Flashing	Sensing movement

Quick Mode

Blue LED	State
ON	After power on for about 3 seconds
OFF	Normal operation

Specifications

- Dimension: S6R 47.4×23.8×14.7mm (L×W×H)
S8R 46.5×26.8×14.1mm (L×W×H)
- Weight: S6R 12.1g S8R 14g
- Number of channels: S6R 6CH (1~6 from conventional channel outputs)
S8R 8CH/16CH (1-8 from conventional channel outputs, 1~16 from SBUS outputs)
- Operating Current: S6R 100mA@5V S8R 120mA@5V
- With RSSI PWM output on board (Δ S8R only): PWM voltage output (0~3.3V), 100Hz, 1500±500 μ s
- Operating Voltage Range: DC 4.0V~10V
- Operating Range: Full Range
- Measuring Range of Gyroscope: ±2000dps
- Measuring Range of Accelerometer: ±4g
- Firmware Upgradeable
- Compatibility: FrSky Transmitters and modules in D16 mode

Note: S6R-EU&S8R-EU only works with Transmitters and modules in D16-EU mode.

Features

- Built-in three-axis gyroscope and three-axis accelerometer sensor module
- Built-in RSSI PWM output (Δ S8R only)
- Built-in battery voltage detection
- Smart Port enabled

If required, SxR could be used as a standard 6/8 channel X series receiver.

Channels

Channel No.	Corresponding parts on the model	Full name
CH1	AIL 1	Aileron
CH2	ELE 1	Elevator
CH3	THR	Throttle
CH4	RUD	Rudder
CH5	AIL 2	Aileron
CH6	ELE 2	Elevator
CH7	User-defined	
CH8	User-defined	
CH9	Receiver Internal Use	Gyro gain adjustment
CH10&CH11	Receiver Internal Use	Flight modes
CH12	Receiver Internal Use	Self-check activation switch

Note:

Only S8R has CH7 and CH8 PWM outputs.
When the value of CH9 is in the center, the Gyro gain is zero. The gain increases as the value gets bigger. Until the value is ±100%, the gain reaches maximum.
CH9 uses absolute values (+ or -). For example, -70% is seen the same as +70%. Use the edit line below in the transmitter mixers to remedy this.
CH9 Edit — Setting CH9 at Weight 50 and offset 50, the assigned pot/slide will work normally.

Quick Mode

Quick Mode is mainly designed for beginners. It supports normal model only, suitable for stabilization mode, manual (six-axis off) mode, automatic level mode and configured through CH10. What's more, an urgent mode is added to configure automatic level mode default through CH12. The precise configuration is written below.

Channel	Position	Flight Mode
CH10	SW Up	Automatic Level Mode
	SW Mid	Stabilization Mode
	SW Down	None
CH12	SW Down	Urgent Mode (Automatic Level Mode)

Note: The default mode of SxR is Quick Mode. When re-flashing firmware of SxR or replacing with a new one, the preset mode will be cleared out, that is to say, SxR will be in Quick Mode.

Δ – If Quick Mode is applied, there is no Knife Edge or (3D) Hover mode.
– CH11 is not used when using Quick Mode.
– Under identical operating conditions, the value of each channel produced by the assigned switch in FrOS are opposite to that in OpenTX. For example, SW Up in FrOS is equal to SW Down in OpenTX.

Flight Mode

Off: When selected, SxR will behave as a normal receiver without any compensation.

Stabilization: When selected, SxR will compensate against external forces (wind) to enhance stability. This function is used to enhance the stability of the model on three axes (Pitch, Roll, and Yaw). CH9 could be used to provide gain control by assigning a pot or a slider, changing the sensitivity of the internal three-axis gyroscope.

Automatic level: When selected, SxR will make the model return to level flight with internal three-axis accelerometer and three-axis gyroscope on AIL and ELE channels after the sticks being released to neutral. Automatic RUD channel works in stabilization mode only.

Hover: When selected, SxR will orientate the model's nose straight up. The mode uses three-axis accelerometer and three-axis gyroscope and RUD, ELE for control.

Note:

ELE and RUD control is automatic. Under this mode, AIL controls the model rotation and THR adjusts the height.
Automatic AIL only works on stability, auto level and knife-edge mode.
Knife-edge mode: When selected, SxR will roll the plane on a certain side (wing points up) with internal three-axis accelerometer and three-axis gyroscope on RUD and AIL. Steering is done with ELE, altitude will be maintained with THR/RUD. Automatic ELE only works on stabilization, auto level and hover modes.

Normal Model	Automatic level
	Off
	Stabilization
	Hover
Normal model (Quick Mode)	Automatic level
	Stabilization
	Off
	Knife-edge
Delta Wing(Elevon)/Flying Wing/V-tail	Automatic level
	Off
	Stabilization

Note: These model types are selected through SxR, PC Config or SxR.Iua.

Normal Mode

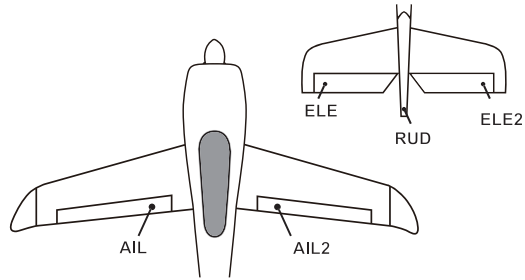

Layout of Normal Type

The available flight modes can be assigned to CH10 and CH11 with three-position switches.

Flight mode	Stabilization	Automatic level	Hover	Knife-Edge	Off
CH10 (3 pos SW)	CH10>M+H (CH10 SW Down)	CH10>M+H (CH10 SW Down)	CH10>M+H (CH10 SW Down)	CH10>M+H (CH10 SW Up)	CH10 SW Mid
CH11(3 pos SW)	M-H<CH11<M+H (CH11 SW Mid)	CH11>M+H (CH11 SW Down)	CH11<M-H (CH11 SW Up)	M-H<CH11<M+H (CH11 SW Mid)	

Delta wing(Elevon) & Flying wing & V-tail

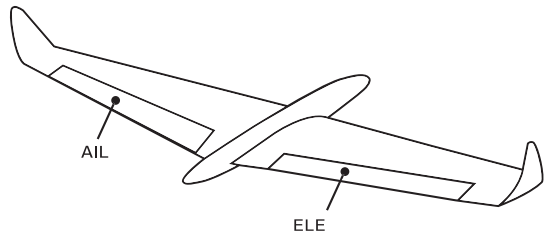

Layout of Delta wing(Elevon)/ Flying wing

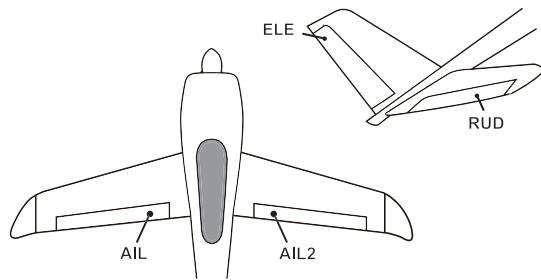

Layout of V-tail

The available flight mode can be assigned to CH10 with a three-position switch.

Flight mode	Stabilization	Auto Level	Off
CH10	CH10>M+H (CH10 SW Down)	CH10<M-H (CH10 SW Up)	CH10 SW Mid

When Delta wing (Elevon)/ Flying wing/ V-tail is selected, there must be no active mixing on the transmitter. SxR must mix all of the AIL (CH1) and ELE (CH2) signals internally. CH4~CH8 is user-defined.

M: \rightarrow represents a neutral signal period (1500 μ s/ 0.0%/ Mid position).

H: \rightarrow represents the minimum time of required signal (50 μ s), + or - to make state/mode change. If the value of Mid position is 1500 μ s, then Low position is from 1000 μ s to 1449 μ s, High position is from 1551 μ s to 2000 μ s.

Note:

When factory settings are used, switch positions above represents corresponding required mode, or just follow the vision in brackets to set the required switch positions for each mode.

Configuration

The SxR receiver needs some configurations before use. Configuration methods are written below:

- FrSky Transmitter (wireless)
- PC software (FrSky STK USB updater/ Airlink / Airlink s)
- FreeLink App (iOS only now)

Configuration parameters:

- Wing type
- Mounting type
- Gain setting
- Offset angle setting
- Accelerometer calibration

FrSky transmitter

- Copy the SxR.lua files on the SD card of the transmitter
- Bind the SxR to the transmitter and run the files.
- Configure the parameters.

PC software Freelink

- Connect SxR as shown below to the FrSky STK usb adapter/ Airlink / Airlink s to PC
- Run the S6R Config.exe / S8R Config.exe software and access the home page.
- Select the correct COM Port.
- Press open to connect with SxR.

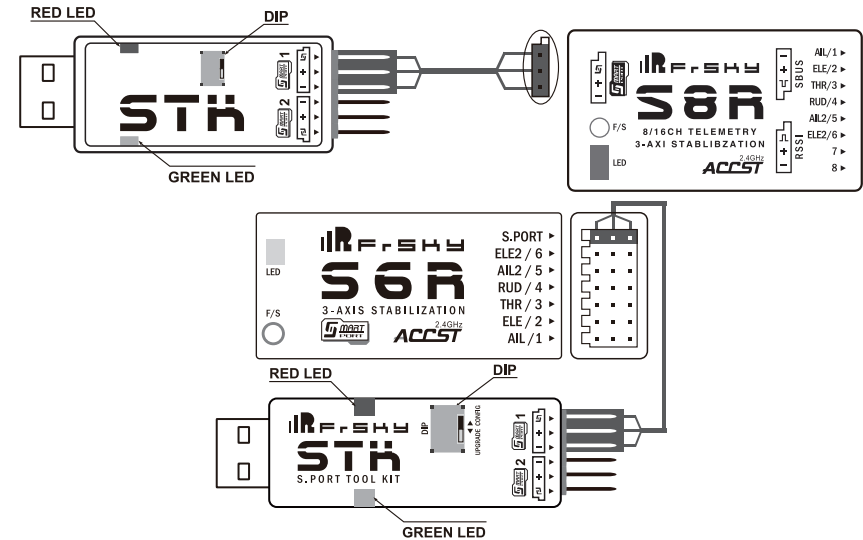

Note:

1. All the files and tools you can get from SxR download zone of FrSky website.
2. To download FreeLink, search FrSky FreeLink in the App store (Android Version coming soon).
3. If your PC does not add another COM port to the Configuration APP list when you plug in the STK dongle, you need to install or repair the PC Drive for the Application.

Below we will take the PC configuration tool as an example to show how to configure the parameters. It will be similar in transmitters with lua file.

The menu screen of home page

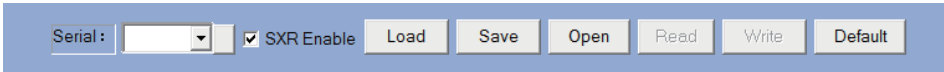

Serial: [Dropdown] Displays the COM port that SxR has connected to. When SxR Enable is not ticked in the check box, SxR functions as a regular 6/8 channel receiver.

- Load** Load Configuration editor with a previously saved file from your PC.
- Save** Save Configuration file to your PC.
- Open** Gives the PC software access to SxR configuration data
- Read** SxR Read data from SxR and display in configuration editor.
- Write** SxR Store currently selected data into the SxR.
- Default** Returns all Configuration settings to the factory defaults

Configuration parameter

Wing Type

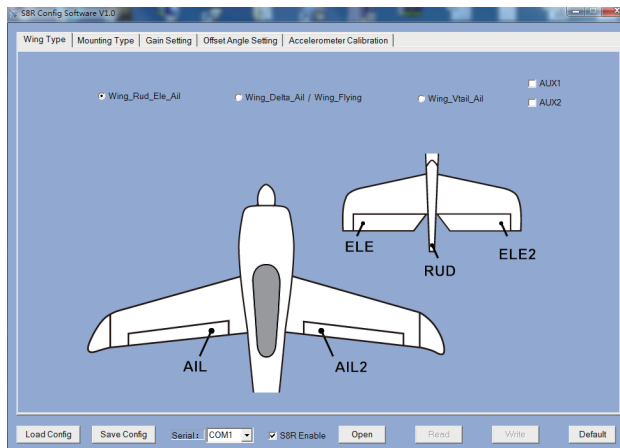

- Option of wing types:
- Wing_Rud_Ele_Ail → Normal model
 - Wing_Delta_Ail/Wing_Flying → Delta Wing (Elevon)/ Flying wing
 - Wing_Vtail_Ail → V-Tail

- AUX1** If selected, all automatic functions are disabled on AIL 2, CH5. CH5 becomes a normal user-defined channel.
- AUX2** If selected, all automatic functions are disabled on ELE 2, CH6. CH6 becomes a normal user-defined channel.

Mounting type

Four Orientations: Level, Bottom, Right and Left up mounting options are available.

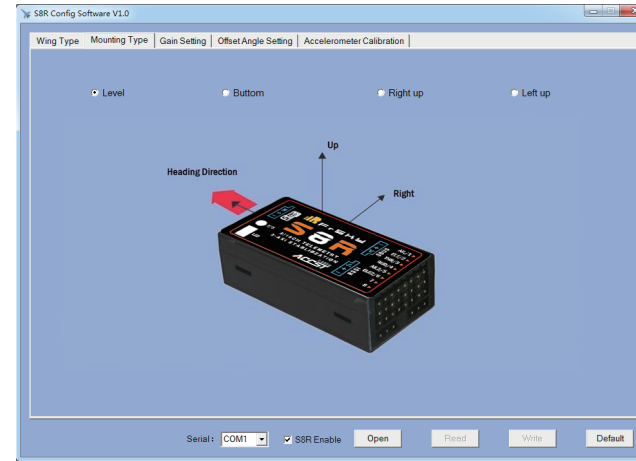

Gain Setting

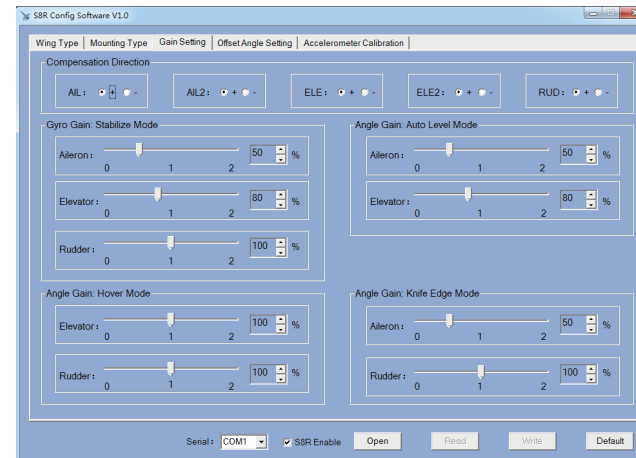

The first part

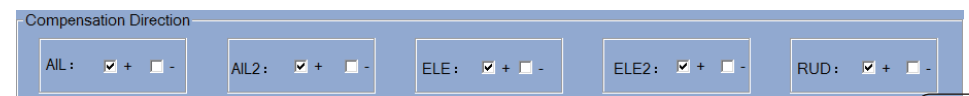

Note:

“+” means positive and “-” means negative (Channel function reversal)
 The function is used to reverse automatic function travels.
 Use SxR in Off mode and your transmitter to reverse any channels otherwise.

The second part

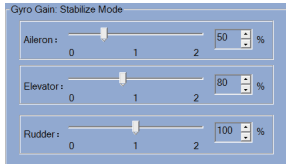

The gain setting under stabilization mode should be set on the channels related to aileron, elevator and rudder.

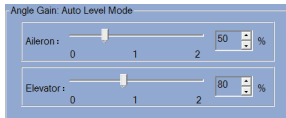

The gain setting under automatic level mode could be set on the channels related to aileron and elevator.

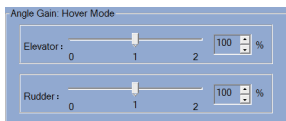

The gain setting under hover mode could be set on the channels related to elevator and rudder.

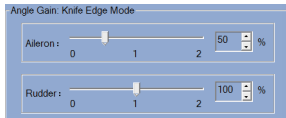

The gain setting under knife edge mode could be set on the channels related to aileron and rudder.
Optional range is from 0 to 200%. 0, 1, 2 refers to 0%, 100% and 200% respectively.

Offset Angle Setting

Due to the possible errors in minor installation and calibration, the function is designed to adjust the attitude of the model. Thus, the user could achieve the best orientation when Auto Level, Hover mode and Knife-edge mode is activated.

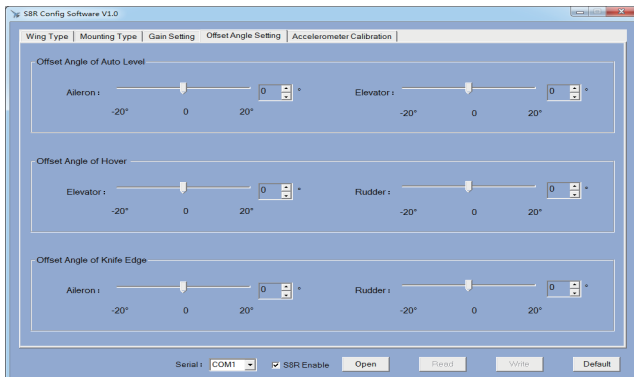

These following options are for fine tuning, in most cases they are not often needed.

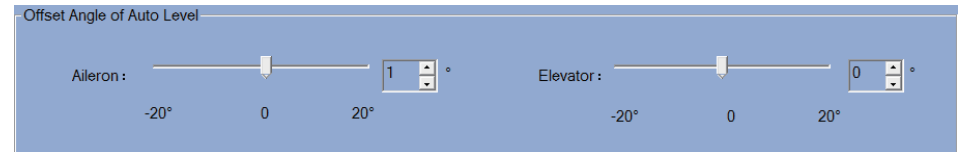

The angle of roll and pitch could be adjusted on the channels related to aileron and elevator. Straight and Level flight could be realized.

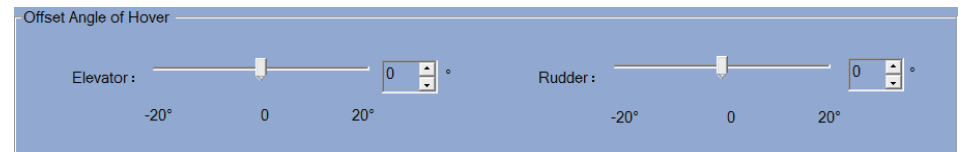

The nose-up angle could be adjusted on the channels related to aileron and elevator. Stationary hover could be realized in calm weather.

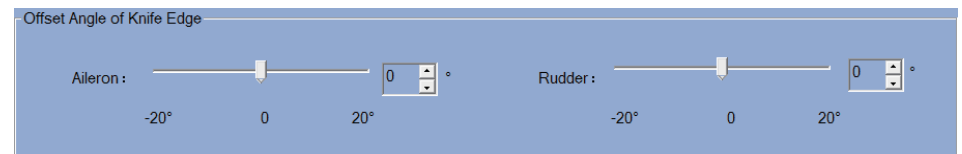

The angle of aileron and rudder could be adjusted on the related channels. Straight and level knife-edge flight could be realized.
Optional range is from -20° to 20°

Accelerometer Calibration

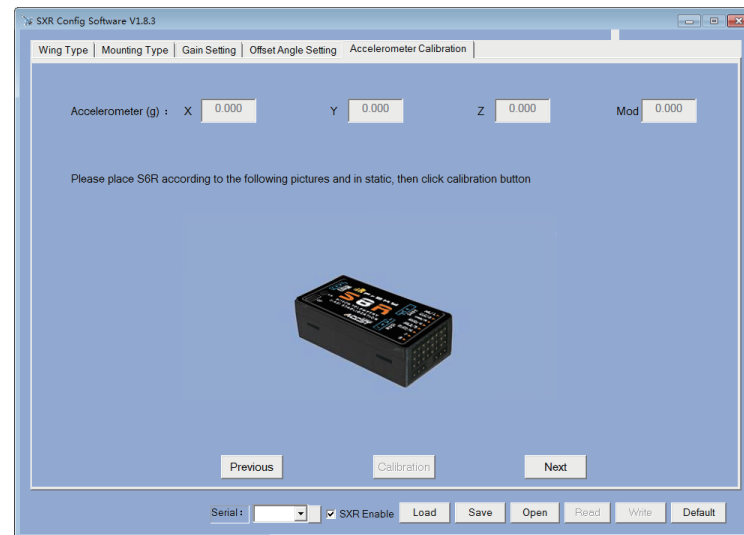

The positive and negative values related to three-axis gyroscope and accelerometer make a total of six values that need to be acquired. Please follow the on-screen instructions.

- Click **Calibration**, then wait until the YELLOW LED stops flashing, indicating the calibration on this orientation has been completed.

Hold the SxR stable during this process.

- Repeat the step above five times (remaining 5 orientations). Placing SxR in the required orientation, ensure all values (X, Y, Z, Mod) are displaying 1.000 with the deviation of ± 0.1 .

- Press **Write** to save the data on SxR when done.

Preflight Preparation

Inspection of flight attitude

To ensure flight safety, checking the compensation direction of the model is strongly recommended.

Activating auto level mode will produce a strong deflection on AIL and ELE, which is used to check the response of aileron and elevator. Also, activating Knife-edge and Hover mode will have the same reaction on the rudder.

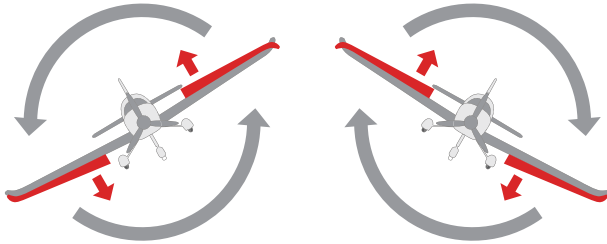

When the plane is rotated left or right (Roll), ailerons should have the correcting actions as illustrated above.

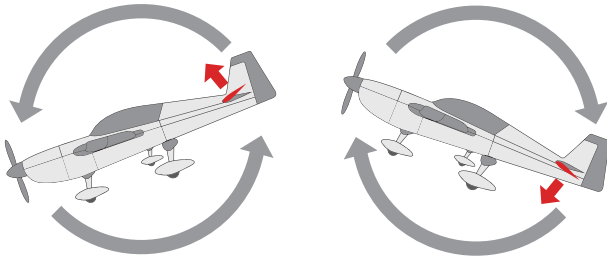

When the plane is rotated up or down (Pitch), elevators should have the correcting actions as illustrated above.

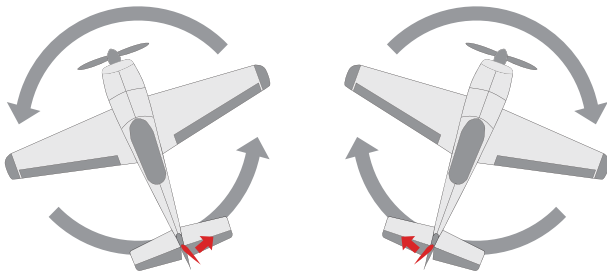

When the plane is rotated to left or right (Yaw), rudders should have the correcting actions as illustrated above.

If the compensation direction is incorrect, please reverse the corresponding channel as illustrated below.

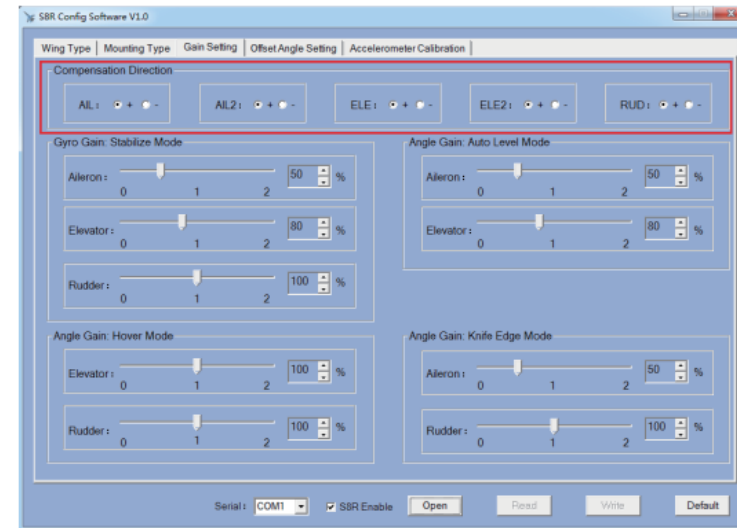

After changing the compensation direction, make sure to check it again on the actual model.

Check everything in OFF mode and auto mode as they can be different.

Self-check

- Before self-check, please place the model on the ground (level surface).
- When the model is flying, **aerodynamic balance is more important than level attitude**, which results in that the model fly at a constant altitude with the nose slightly pointing up at low speed. To avoid the nose-diving of the model at high air speed, the user must insure that the model is placed at a level or slightly-nose-up attitude during self-check.
- Always install SxR straight and level in the model. If required, PC software could be used to adjust the angle of attack to realize the required setting. If the values set by the user is bigger than average ones, we advise to recheck the installation orientation of SxR.

Steps

- Turn on the transmitter and ensure that Ail (CH1), ELE (CH2), RUD (CH4), AIL 2(CH5) and ELE 2(CH6) are in the neutral position.
- Power on the model and start SxR self-check. Ensure the wings are Level and the Attitude is slightly Nose Up. Please don't touch/ move the model until self-check finishes, or it may corrupt the calibration settings created during the procedure.
- Press the F/S button on SxR or move the three-position sticks bound to CH12 three times in 3 seconds (up, mid, down). Then the BLUE LED will turn on, indicating self-check procedure is initiated. After that, the corresponding parts on the model will move. The BLUE LED will turn off, indicating self-check is ready for next step — Midpoint/Endpoint calibration.
- Move the sticks bound to CH1~CH6/CH8 (except the Throttle stick) and check the channel output limits, ensuring that the signal outputs of SxR will not damage the corresponding parts on the model.
- In the end, SxR will save the zero points of the gyro, auto level angle, wings level positions and servo channel limits. Self-check ends.

- ⊗ Never operate the stick bound to CH12 during flight session. If so, it will trigger self-check and may cause the model to crash.
- ⊗ Never cut off the power supply of SxR during self-check, or self-check will fail.

Note: When setting output limits, please ensure the transmitter is not operating at low rates.

Setup Procedure

- Calibrate SxR with the PC software or transmitter and install it into the model. Insure the settings of wing type and mounting type are identical to the intended model installation.
- Turn on the transmitter and reduce the value of servo endpoint setting. Ensure self-check mode will not damage the corresponding parts on the model.
- Assign a knob/slider to CH9, then real-time gain adjustment capabilities of SxR will be activated.
- Assign three-position switches to CH10 and CH11 with the purpose of switching available flight modes.
- Power on the model and check the deflection direction of each related parts on the model. Make sure the switch assigned to flight modes is correct and the compensation direction of the gyro is set as intended on AIL, RUD and ELE.
- Make a self-check for SxR if necessary. Disconnecting the power on SxR will not lose any set parameter.

Note:

- 1. Self-check may be failed and should be repeated correctly under these conditions:**
Have any control surface that travel in one direction only after setup.
Have a control surface that travel differently in one direction or jitter after setup.
If the plane rises or dives slightly or turn to one side when in Auto Level Mode.
- 2. If the plane rises or dives sharply or turns to one side sharply when in Auto Level Mode, it is possible that one surface needs to be reversed in the Configuration Setup.**
- 3. If surfaces travel in the wrong direction under OFF mode, reverse the channel with the transmitter.**
- 4. If Toggling CH12 will not activate Self check, make sure the transmitter is in D16 Mode and have at least 12 Channels active. D16 Mode only has 8 channels activate as default in old openTX firmware of transmitter.**
- 5. When using Delta wing or flying wing, depending on the mechanics of a particular servo installation and linkage to the control surfaces, sometimes it happens that the reserve function of the two servo outputs cannot make the control surfaces respond correctly in auto-level and stabilization mode. The solution is to swap the two connections to the receiver, then set the servo directions for correct operation.**

FrSky is continuously adding features and improvements to our products. To get the most from your product, please check the download section of the FrSky website www.frsky-rc.com for the latest update firmware and manuals